

AWD150-15
Best. - Nr.: 700 5885

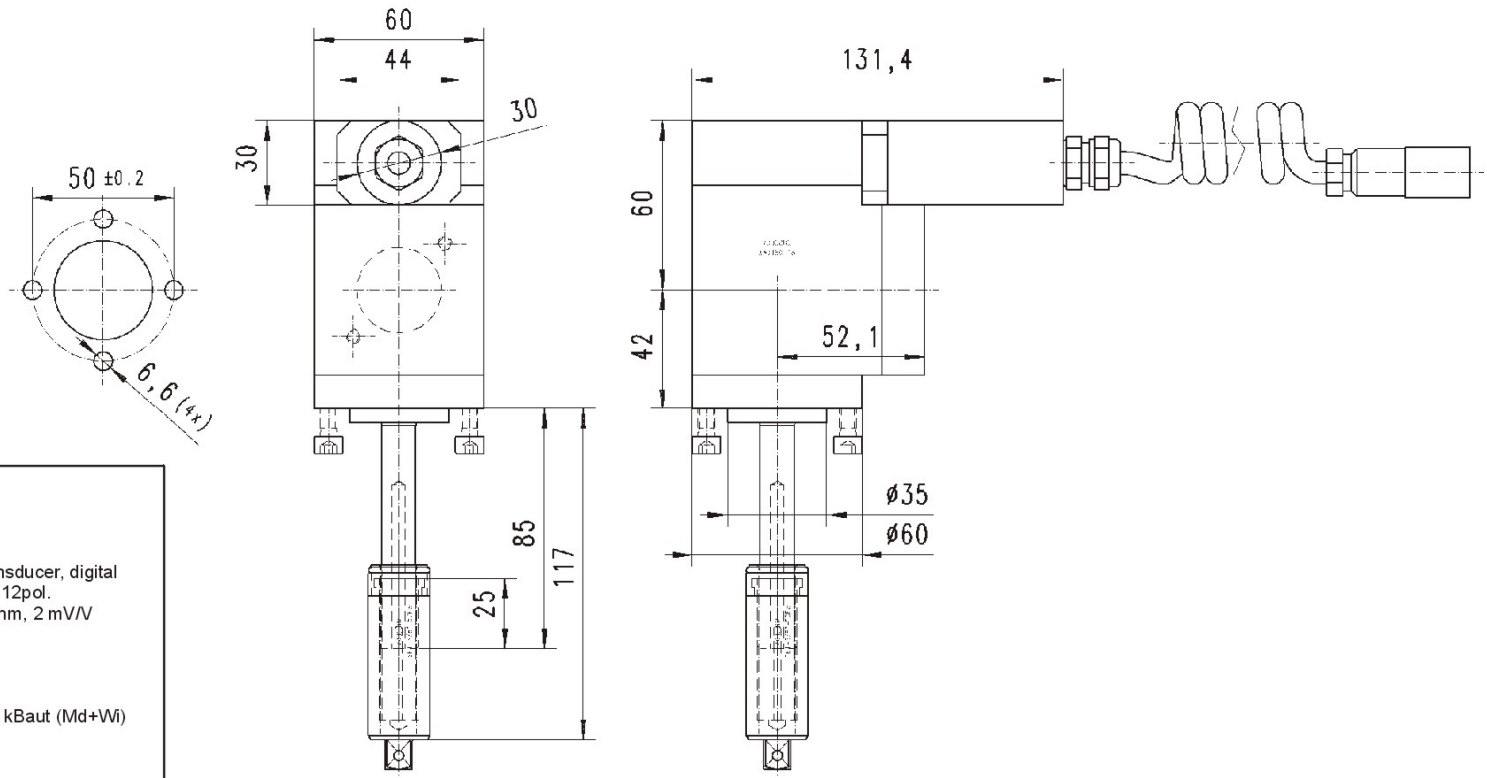

Technical data:

General data:

Type AOD.....	Action measurement transducer, digital
Flanged plug-in connector	Make Binder, Serie 723, 12pol.
Type of sensor	DMS-full bridge, 1000 Ohm, 2 mV/V
Supply voltage	+ 12V (+/- 5%)
Zero point difference	< 1% vom Nennwert
Current consumption	140 mA
Sampling rate	3,31 kHz
Communication	digital, asynchron, 230,4 kBaud (Md+Wi)
Communication Bus	RS485
Torque resolution	12 Bit
Angle trace A, B (Option)	0,5° resolution
Rating memory	internally in EEPROM
Rating memory Bus	I ² C

Pin assignment:

A	+ 12V	Transmitter supply
B	GND	Ground
C	RX / TX	Data line RS485
D	NRX / NTX	Data line RS485
E	DIR	Data direction switch
F	SDA	serial Data (I ² C)
G	SCL	serial Clock (I ² C)
H	nc.	
J	Wi-V	Winkel leading (Option)
K	Wi-N	Winkel lagging (Option)
L	nc.	
M	nc.	